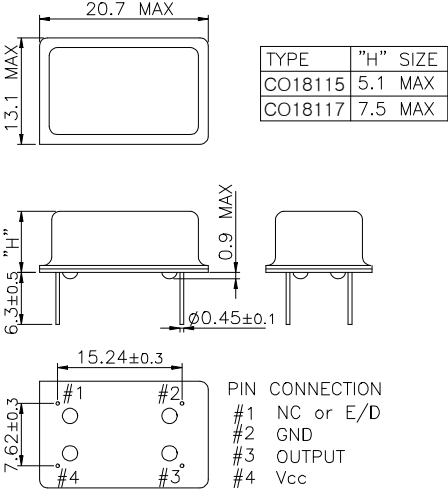
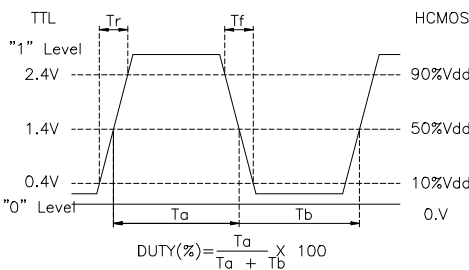
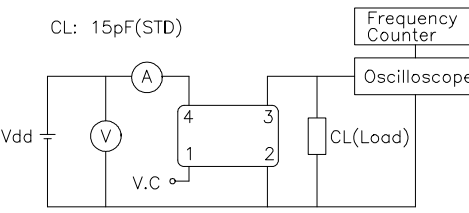

Excequal

Clock Oscillator

CO1811

1KHz ~ 800MHz
HCMOS/TTL 15pF or 10TTL

MECHANICAL DIMENSIONS	ELECTRICAL SPECIFICATION																																																	
 <table border="1" data-bbox="383 638 574 716"> <tr> <th>TYPE</th> <th>"H" SIZE</th> </tr> <tr> <td>CO18115</td> <td>5.1 MAX</td> </tr> <tr> <td>CO18117</td> <td>7.5 MAX</td> </tr> </table>	TYPE	"H" SIZE	CO18115	5.1 MAX	CO18117	7.5 MAX	<table border="1"> <tr> <td>Frequency range</td> <td>1.000KHz to 800.000MHz All combination of Frequency range Vs. Package type might not be available ,please contact factory</td> </tr> </table>		Frequency range	1.000KHz to 800.000MHz All combination of Frequency range Vs. Package type might not be available ,please contact factory																																								
TYPE	"H" SIZE																																																	
CO18115	5.1 MAX																																																	
CO18117	7.5 MAX																																																	
Frequency range	1.000KHz to 800.000MHz All combination of Frequency range Vs. Package type might not be available ,please contact factory																																																	
<p>OUTPUT WAVEFORM</p> 	<table border="1"> <tr> <td>Frequency Stability vs. Temperature vs. Aging</td> <td>± 10 ppm to ±50ppm ±3.0 ppm max/ year</td> </tr> </table>		Frequency Stability vs. Temperature vs. Aging	± 10 ppm to ±50ppm ±3.0 ppm max/ year																																														
Frequency Stability vs. Temperature vs. Aging	± 10 ppm to ±50ppm ±3.0 ppm max/ year																																																	
<p>TEST CIRCUIT</p> 	<table border="1"> <tr> <td>Temperature Range Operating Storage</td> <td>See Table 2 -55°C to 105°C</td> </tr> </table>		Temperature Range Operating Storage	See Table 2 -55°C to 105°C																																														
Temperature Range Operating Storage	See Table 2 -55°C to 105°C																																																	
<p>ENVIRONMENTAL & MECHANICAL SPECIFICATION</p> <table border="1" data-bbox="638 1608 1517 1765"> <tr> <td>Shock</td> <td>MIL-STD-883C, Method 2002, Condition B</td> </tr> <tr> <td>Vibration</td> <td>MIL-STD-883C, Method 2007, Condition A</td> </tr> <tr> <td>Solderability</td> <td>MIL-STD-883C, Method 2003</td> </tr> <tr> <td>Seal integrity</td> <td>MIL-STD-883C, Method 1014, Condition C & A2</td> </tr> <tr> <td>Marking</td> <td>MIL-STD-202F, Method 215</td> </tr> </table>	Shock	MIL-STD-883C, Method 2002, Condition B	Vibration	MIL-STD-883C, Method 2007, Condition A	Solderability	MIL-STD-883C, Method 2003	Seal integrity	MIL-STD-883C, Method 1014, Condition C & A2	Marking	MIL-STD-202F, Method 215	<table border="1"> <tr> <td>Supply Voltage</td> <td>3.3V ± 5% 5.0V ± 5%</td> </tr> </table>		Supply Voltage	3.3V ± 5% 5.0V ± 5%																																				
Shock	MIL-STD-883C, Method 2002, Condition B																																																	
Vibration	MIL-STD-883C, Method 2007, Condition A																																																	
Solderability	MIL-STD-883C, Method 2003																																																	
Seal integrity	MIL-STD-883C, Method 1014, Condition C & A2																																																	
Marking	MIL-STD-202F, Method 215																																																	
Supply Voltage	3.3V ± 5% 5.0V ± 5%																																																	
<p>TABLE1</p> <table border="1" data-bbox="638 1780 925 2087"> <thead> <tr> <th>Symbol</th> <th>Stability</th> </tr> </thead> <tbody> <tr><td>10</td><td>± 10ppm</td></tr> <tr><td>15</td><td>± 15ppm</td></tr> <tr><td>20</td><td>± 20ppm</td></tr> <tr><td>30</td><td>± 30ppm</td></tr> <tr><td>50</td><td>± 50ppm</td></tr> <tr><td>100</td><td>±100ppm</td></tr> </tbody> </table>	Symbol	Stability	10	± 10ppm	15	± 15ppm	20	± 20ppm	30	± 30ppm	50	± 50ppm	100	±100ppm	<table border="1"> <tr> <td>Input Current 3.3 V , 5V</td> <td>1.000KHz ~ 40.000MHz ~ 800.000MHz 15mA max ~ 30mA max ~ 100mA max</td> </tr> </table>		Input Current 3.3 V , 5V	1.000KHz ~ 40.000MHz ~ 800.000MHz 15mA max ~ 30mA max ~ 100mA max																																
Symbol	Stability																																																	
10	± 10ppm																																																	
15	± 15ppm																																																	
20	± 20ppm																																																	
30	± 30ppm																																																	
50	± 50ppm																																																	
100	±100ppm																																																	
Input Current 3.3 V , 5V	1.000KHz ~ 40.000MHz ~ 800.000MHz 15mA max ~ 30mA max ~ 100mA max																																																	
<p>TABLE2</p> <table border="1" data-bbox="941 1780 1517 2087"> <thead> <tr> <th>Symbol</th> <th>Temp.</th> <th>Symbol</th> <th>Temp.</th> </tr> </thead> <tbody> <tr><td>0</td><td>0°C</td><td>A</td><td>50°C</td></tr> <tr><td>1</td><td>-10°C</td><td>B</td><td>60°C</td></tr> <tr><td>2</td><td>-20°C</td><td>C</td><td>70°C</td></tr> <tr><td>3</td><td>-30°C</td><td>D</td><td>75°C</td></tr> <tr><td>4</td><td>-40°C</td><td>E</td><td>80°C</td></tr> <tr><td></td><td></td><td>F</td><td>85°C</td></tr> </tbody> </table>	Symbol	Temp.	Symbol	Temp.	0	0°C	A	50°C	1	-10°C	B	60°C	2	-20°C	C	70°C	3	-30°C	D	75°C	4	-40°C	E	80°C			F	85°C	<table border="1"> <tr> <td>Output characteristics HCMOS / TTL</td> <td> <table border="1"> <tr> <th></th> <th>HCMOS</th> <th>TTL</th> </tr> <tr> <td>Logic "1"</td> <td>90% Vdd min</td> <td>2.4V min</td> </tr> <tr> <td>Logic "0"</td> <td>10% Vdd max</td> <td>0.4V min</td> </tr> <tr> <td>Load</td> <td>15pF</td> <td>10TTL</td> </tr> <tr> <td>Duty Cycle</td> <td>40/60</td> <td>40/60</td> </tr> <tr> <td>Rise & Fall</td> <td>10nS max</td> <td>10nS max</td> </tr> </table> </td> </tr> </table>		Output characteristics HCMOS / TTL	<table border="1"> <tr> <th></th> <th>HCMOS</th> <th>TTL</th> </tr> <tr> <td>Logic "1"</td> <td>90% Vdd min</td> <td>2.4V min</td> </tr> <tr> <td>Logic "0"</td> <td>10% Vdd max</td> <td>0.4V min</td> </tr> <tr> <td>Load</td> <td>15pF</td> <td>10TTL</td> </tr> <tr> <td>Duty Cycle</td> <td>40/60</td> <td>40/60</td> </tr> <tr> <td>Rise & Fall</td> <td>10nS max</td> <td>10nS max</td> </tr> </table>		HCMOS	TTL	Logic "1"	90% Vdd min	2.4V min	Logic "0"	10% Vdd max	0.4V min	Load	15pF	10TTL	Duty Cycle	40/60	40/60	Rise & Fall	10nS max	10nS max
Symbol	Temp.	Symbol	Temp.																																															
0	0°C	A	50°C																																															
1	-10°C	B	60°C																																															
2	-20°C	C	70°C																																															
3	-30°C	D	75°C																																															
4	-40°C	E	80°C																																															
		F	85°C																																															
Output characteristics HCMOS / TTL	<table border="1"> <tr> <th></th> <th>HCMOS</th> <th>TTL</th> </tr> <tr> <td>Logic "1"</td> <td>90% Vdd min</td> <td>2.4V min</td> </tr> <tr> <td>Logic "0"</td> <td>10% Vdd max</td> <td>0.4V min</td> </tr> <tr> <td>Load</td> <td>15pF</td> <td>10TTL</td> </tr> <tr> <td>Duty Cycle</td> <td>40/60</td> <td>40/60</td> </tr> <tr> <td>Rise & Fall</td> <td>10nS max</td> <td>10nS max</td> </tr> </table>		HCMOS	TTL	Logic "1"	90% Vdd min	2.4V min	Logic "0"	10% Vdd max	0.4V min	Load	15pF	10TTL	Duty Cycle	40/60	40/60	Rise & Fall	10nS max	10nS max																															
	HCMOS	TTL																																																
Logic "1"	90% Vdd min	2.4V min																																																
Logic "0"	10% Vdd max	0.4V min																																																
Load	15pF	10TTL																																																
Duty Cycle	40/60	40/60																																																
Rise & Fall	10nS max	10nS max																																																
<p>Pin 1 Tri-State Input Voltage</p>	<table border="1"> <tr> <td>No Connection</td> <td>Enable Output</td> </tr> <tr> <td>Vh ≥ 2.0 Vdc</td> <td>Enable Output</td> </tr> <tr> <td>Vi ≤ 0.8 Vdc</td> <td>Disable Output</td> </tr> </table>		No Connection	Enable Output	Vh ≥ 2.0 Vdc	Enable Output	Vi ≤ 0.8 Vdc	Disable Output																																										
No Connection	Enable Output																																																	
Vh ≥ 2.0 Vdc	Enable Output																																																	
Vi ≤ 0.8 Vdc	Disable Output																																																	