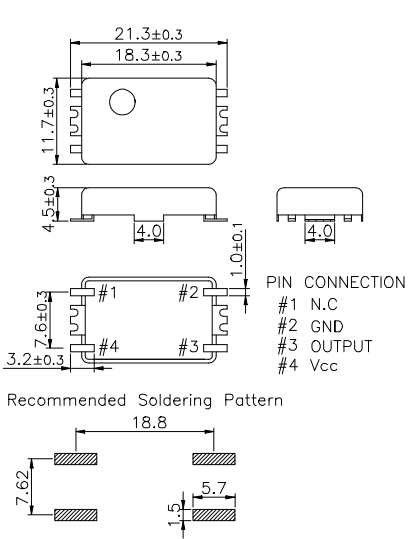
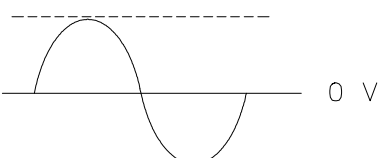
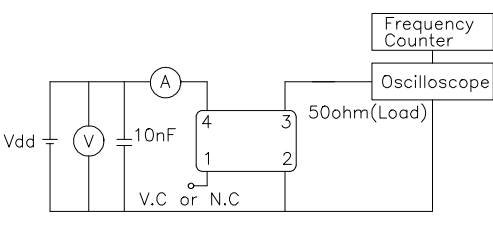

MECHANICAL DIMENSIONS	ELECTRICAL SPECIFICATION																																									
 <p>21.3±0.3 18.3±0.3 11.7±0.3 4.5±0.3 4.0 1.0±0.1 4.0 7.6±0.3 3.2±0.3 #1 N.C #2 GND #3 OUTPUT #4 Vcc Recommended Soldering Pattern 18.8 7.62 1.5 5.7</p>	<table border="1"> <tr> <td>Frequency range</td> <td colspan="2">6.000MHz to 190.000MHz</td> </tr> <tr> <td>Frequency Stability vs. Temperature vs. Supply Voltage vs. Load vs. Aging</td> <td colspan="2">±0.5 ppm to ±5.0ppm ±0.1 / ±0.2 ppm max / Vdd ± 5% ±0.2 ppm max /15pF ±10% ±1.0 ppm max/ year</td> </tr> <tr> <td>Temperature Range Operating Storage</td> <td colspan="2">See Table 2 -55°C to 125°C</td> </tr> <tr> <td>Supply Voltage</td> <td colspan="2">3.3V ± 5% 5.0V ± 5%</td> </tr> <tr> <td>Input Current  Sinewave</td> <td>6.00MHz 12.0mA max</td> <td>~ 190.000MHz ~ 30mA max</td> </tr> <tr> <td>Output characteristics</td> <td>Level 3.3V 5.0V Load</td> <td>Sinewave 0 dBm typ 10 dBm typ 50Ω</td> </tr> <tr> <td>Phase Noise (typical) 20MHz offset</td> <td colspan="2">-80 dBc / Hz @ 10Hz -120 dBc / Hz @ 100Hz -135 dBc / Hz @ 1KHz -140 dBc / Hz @ 10KHz -145 dBc / Hz @100KHz</td> </tr> <tr> <td>Frequency Adjustment</td> <td colspan="2">±3ppm min by internal trimmer</td> </tr> </table>		Frequency range	6.000MHz to 190.000MHz		Frequency Stability vs. Temperature vs. Supply Voltage vs. Load vs. Aging	±0.5 ppm to ±5.0ppm ±0.1 / ±0.2 ppm max / Vdd ± 5% ±0.2 ppm max /15pF ±10% ±1.0 ppm max/ year		Temperature Range Operating Storage	See Table 2 -55°C to 125°C		Supply Voltage	3.3V ± 5% 5.0V ± 5%		Input Current  Sinewave	6.00MHz 12.0mA max	~ 190.000MHz ~ 30mA max	Output characteristics	Level 3.3V 5.0V Load	Sinewave 0 dBm typ 10 dBm typ 50Ω	Phase Noise (typical) 20MHz offset	-80 dBc / Hz @ 10Hz -120 dBc / Hz @ 100Hz -135 dBc / Hz @ 1KHz -140 dBc / Hz @ 10KHz -145 dBc / Hz @100KHz		Frequency Adjustment	±3ppm min by internal trimmer																	
Frequency range	6.000MHz to 190.000MHz																																									
Frequency Stability vs. Temperature vs. Supply Voltage vs. Load vs. Aging	±0.5 ppm to ±5.0ppm ±0.1 / ±0.2 ppm max / Vdd ± 5% ±0.2 ppm max /15pF ±10% ±1.0 ppm max/ year																																									
Temperature Range Operating Storage	See Table 2 -55°C to 125°C																																									
Supply Voltage	3.3V ± 5% 5.0V ± 5%																																									
Input Current  Sinewave	6.00MHz 12.0mA max	~ 190.000MHz ~ 30mA max																																								
Output characteristics	Level 3.3V 5.0V Load	Sinewave 0 dBm typ 10 dBm typ 50Ω																																								
Phase Noise (typical) 20MHz offset	-80 dBc / Hz @ 10Hz -120 dBc / Hz @ 100Hz -135 dBc / Hz @ 1KHz -140 dBc / Hz @ 10KHz -145 dBc / Hz @100KHz																																									
Frequency Adjustment	±3ppm min by internal trimmer																																									
<p><b>OUTPUT WAVEFORM</b></p> 	<p><b>ENVIROMENTAL &amp; MECHANICAL SPECIFICATION</b></p> <table border="1"> <tr> <td>Shock</td> <td>MIL-STD-883C, Method 2002, Condition B</td> </tr> <tr> <td>Vibration</td> <td>MIL-STD-883C, Method 2007, Condition A</td> </tr> <tr> <td>Solderability</td> <td>MIL-STD-883C, Method 2003</td> </tr> <tr> <td>Seal integrity</td> <td>MIL-STD-883C, Method 1014, Condition C &amp; A2</td> </tr> <tr> <td>Marking</td> <td>MIL-STD-202F, Method 215</td> </tr> </table>		Shock	MIL-STD-883C, Method 2002, Condition B	Vibration	MIL-STD-883C, Method 2007, Condition A	Solderability	MIL-STD-883C, Method 2003	Seal integrity	MIL-STD-883C, Method 1014, Condition C & A2	Marking	MIL-STD-202F, Method 215																														
Shock	MIL-STD-883C, Method 2002, Condition B																																									
Vibration	MIL-STD-883C, Method 2007, Condition A																																									
Solderability	MIL-STD-883C, Method 2003																																									
Seal integrity	MIL-STD-883C, Method 1014, Condition C & A2																																									
Marking	MIL-STD-202F, Method 215																																									
<p><b>TEST CIRCUIT</b></p> 	<table border="1"> <thead> <tr> <th colspan="2">TABLE1</th> <th colspan="2">TABLE2</th> </tr> <tr> <th>Symbol</th> <th>Stability</th> <th>Symbol</th> <th>Temp.</th> </tr> </thead> <tbody> <tr> <td>05</td> <td>±0.5ppm</td> <td>0</td> <td>0°C</td> </tr> <tr> <td>10</td> <td>±1.0ppm</td> <td>A</td> <td>50°C</td> </tr> <tr> <td>15</td> <td>±1.5ppm</td> <td>1</td> <td>-10°C</td> </tr> <tr> <td>20</td> <td>±2.0ppm</td> <td>2</td> <td>-20°C</td> </tr> <tr> <td>25</td> <td>±2.5ppm</td> <td>3</td> <td>-30°C</td> </tr> <tr> <td>30</td> <td>±3.0ppm</td> <td>4</td> <td>-40°C</td> </tr> <tr> <td>35</td> <td>±3.5ppm</td> <td></td> <td></td> </tr> <tr> <td>50</td> <td>±5.0ppm</td> <td>F</td> <td>85°C</td> </tr> </tbody> </table>		TABLE1		TABLE2		Symbol	Stability	Symbol	Temp.	05	±0.5ppm	0	0°C	10	±1.0ppm	A	50°C	15	±1.5ppm	1	-10°C	20	±2.0ppm	2	-20°C	25	±2.5ppm	3	-30°C	30	±3.0ppm	4	-40°C	35	±3.5ppm			50	±5.0ppm	F	85°C
TABLE1		TABLE2																																								
Symbol	Stability	Symbol	Temp.																																							
05	±0.5ppm	0	0°C																																							
10	±1.0ppm	A	50°C																																							
15	±1.5ppm	1	-10°C																																							
20	±2.0ppm	2	-20°C																																							
25	±2.5ppm	3	-30°C																																							
30	±3.0ppm	4	-40°C																																							
35	±3.5ppm																																									
50	±5.0ppm	F	85°C																																							