

MECHANICAL DIMENSIONS	ELECTRICAL SPECIFICATION
-----------------------	--------------------------

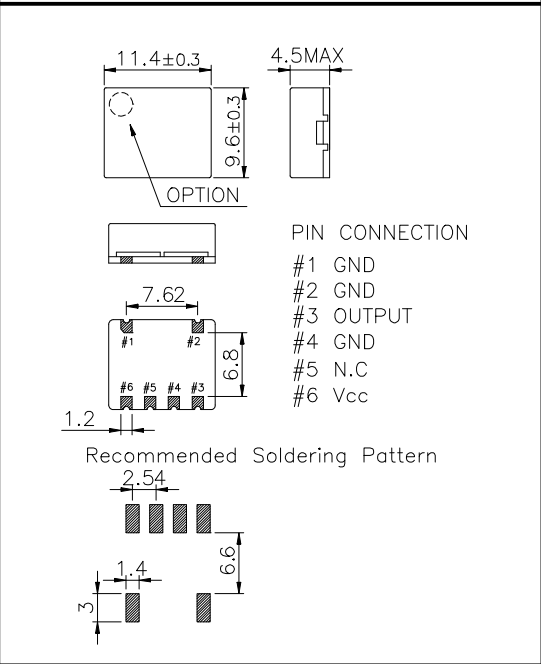

Frequency range	10.000MHz to 50.000MHz Contact us if need high frequency		
Frequency Stability vs. Temperature vs. Supply Voltage vs. Load vs. Aging	±0.5 ppm to ±5.0ppm ±0.1 / ±0.2 ppm max / Vdd ± 5% ±0.2 ppm max /15pF ±10% ±1.0 ppm max/ year		
Temperature Range Operating Storage	See Table 2 -55°C to 125°C		
Supply Voltage	3.3V ± 5% 5.0V ± 5%		
Input Current  Sinewave	10.00MHz 12.0mA max	~	50.000MHz 20mA max
Output characteristics	Level 3.3V 5.0V	Sinewave 0 dBm typ 10 dBm typ	Load 50Ω
Phase Noise (typical) 20MHz offset	-80 dBc / Hz @ 10Hz -120 dBc / Hz @ 100Hz -135 dBc / Hz @ 1KHz -140 dBc / Hz @ 10KHz -145 dBc / Hz @100KHz		
Frequency Adjustment	±3ppm min by internal trimmer (OPTION)		

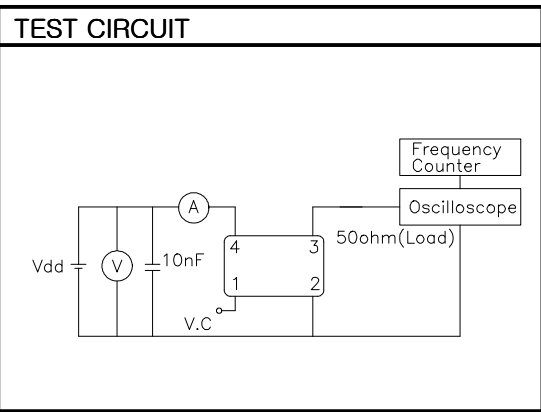
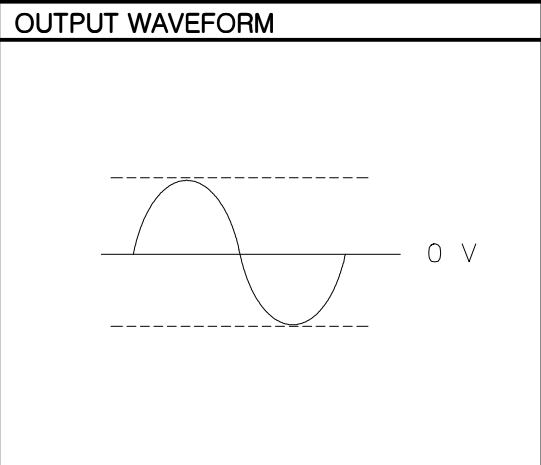

**ENVIROMENTAL & MECHANICAL SPECIFICATION**

Shock	MIL-STD-883C, Method 2002, Condition B
Vibration	MIL-STD-883C, Method 2007, Condition A
Solderability	MIL-STD-883C, Method 2003
Seal integrity	MIL-STD-883C, Method 1014, Condition C & A2
Marking	MIL-STD-202F, Method 215

**TABLE1**

Symbol	Stability
05	±0.5ppm
10	±1.0ppm
15	±1.5ppm
20	±2.0ppm
25	±2.5ppm
30	±3.0ppm
35	±3.5ppm
50	±5.0ppm

**TABLE2**

Symbol	Temp.	Symbol	Temp.
0	0°C	A	50°C
1	-10°C	B	60°C
2	-20°C	C	70°C
3	-30°C	D	75°C
4	-40°C	E	80°C
		F	85°C