

MECHANICAL DIMENSIONS ELECTRICAL SPECIFICATION

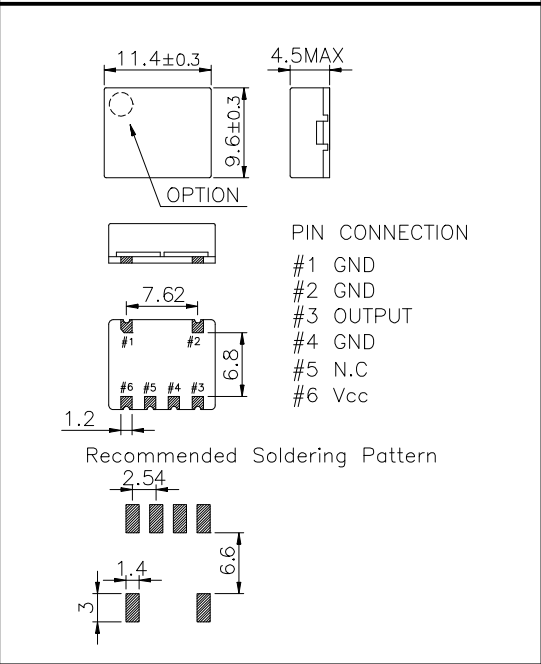

Frequency range	10.000MHz to 40.000MHz Contact us if need high frequency	
Frequency Stability vs. Temperature vs. Supply Voltage vs. Load vs. Aging	±0.5 ppm to ±5.0ppm ±0.2 ppm max / Vdd ± 5% ±0.2 ppm max /15pF ±10% ±1.0 ppm max/ year	
Temperature Range Operating Storage	See Table 2 -55°C to 125°C	
Supply Voltage	3.3V ± 5% 5.0V ± 5%	
Input Current Clipped sinewave	10.00MHz 2.0mA max	~ 40.000MHz ~ 4mA max
Output characteristics	Clipped sinewave Level 3.3V 0.8Vp-p min 5.0V 1.0Vp-p min Load 10kΩ//10pF	
Phase Noise (typical) 20MHz offset	-80 dBc / Hz @ 10Hz -120 dBc / Hz @ 100Hz -135 dBc / Hz @ 1KHz -140 dBc / Hz @ 10KHz -145 dBc / Hz @100KHz	
Frequency Adjustment	±3ppm min by internal trimmer (OPTION)	

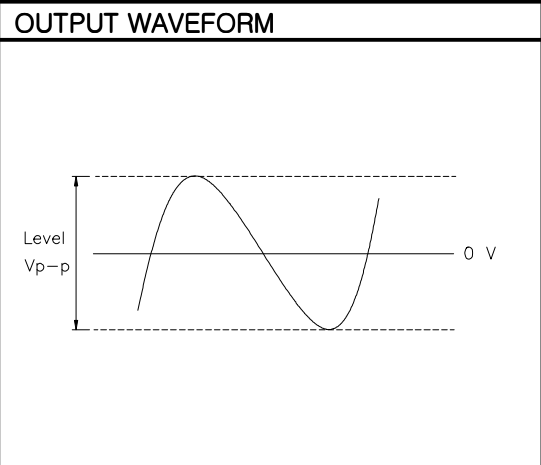

TEST CIRCUIT

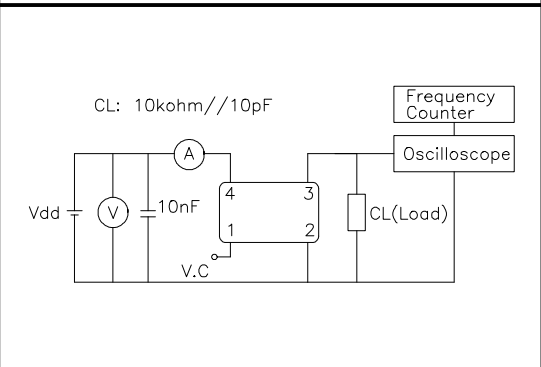

ENVIROMENTAL & MECHANICAL SPECIFICATION

Shock	MIL-STD-883C, Method 2002, Condition B
Vibration	MIL-STD-883C, Method 2007, Condition A
Solderability	MIL-STD-883C, Method 2003
Seal integrity	MIL-STD-883C, Method 1014, Condition C & A2
Marking	MIL-STD-202F, Method 215

TABLE1

Symbol	Stability
05	±0.5ppm
10	±1.0ppm
15	±1.5ppm
20	±2.0ppm
25	±2.5ppm
30	±3.0ppm
35	±3.5ppm
50	±5.0ppm

TABLE2

Symbol	Temp.	Symbol	Temp.
0	0°C	A	50°C
1	-10°C	B	60°C
2	-20°C	C	70°C
3	-30°C	D	75°C
4	-40°C	E	80°C
		F	85°C